

SMART MS 300 Power Supply System

▪ Solar Power Set I

Stand-Alone Solar AC/DC Power Supply

Extendable "plug & play" solar home system for basic 230 / 110V AC and 12V DC power supply. The power set consists of a **compact SMART Mini Solar (MS) 300 unit** with built-in solar charge regulator and "mod. sine wave" inverter, a **solar generator** as charging system and a maintenance-free **battery bank** for energy storage. The set will be delivered as "installation-ready" power package and is thus provided with **mounting system for solar modules** and all necessary **cabling** for easy wiring.

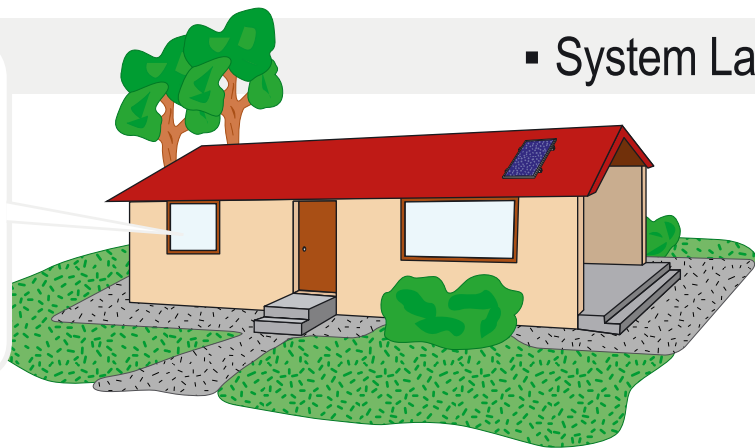
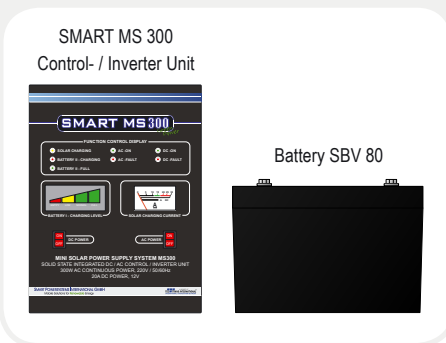

▪ System Layout

Main Components of Power Set

Component	Qty.	Description	Acknowledgements
Control / Inverter Unit	1	SMART MS 300 mod. sine 230V AC, 50/60Hz; 300W cont. / 700W surge power; 20A / 12V DC power; 30A / 24V max. solar charging current; dimensions (l x w x h): 240x200x100mm ³ ; net weight: 4.0kg	optional 110-120V AC, 60Hz 2 years warranty CE Declaration, ISO9001/2000
Solar Charging System	1	Solar Module SM 85 polycrystalline with aluminium frame; 85Wp / 12V; dimensions (l x w x h): 1007x652x36mm ³ ; net weight: 8.3kg	2 years product warranty 25 years performance guarantee (80%) all certifications (ISPRA, ISO)
Storage System	1	Battery SBV 80 / 12 maintenance-free AGM; 80Ah (C = 20h) / 12V; dimensions (l x w x h): 259x168x208mm ³ ; net weight: 23.7kg	1 year product warranty 10 years life expectancy CE Declaration, ISO9001/2000

System Wiring Scheme

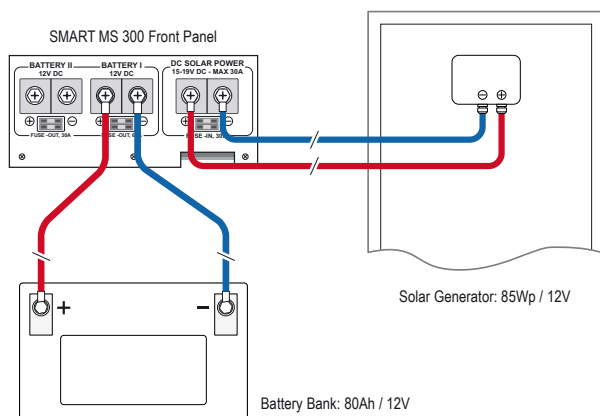

System Summary / Technical Data

AC Power output:	cont. 300W / surge 700W
DC Power output:	20A / 12V
Battery Storage capacity:	80Ah / 12V
Installed PV Power:	85Wp
Avg. Daily PV Charging Capacity:	
3 kWh/m ² /day	255Wh
4 kWh/m ² /day	340Wh
5 kWh/m ² /day	425Wh
6 kWh/m ² /day	510Wh
Total weight of package:	approx. 45kg

SMART MS 300 Power Supply System

▪ Solar Power Set I

System Performance

The Solar Power Set II will supply 230V, 50/60Hz or 115V, 50/60Hz (mod. sine) lights and household appliances as shown in **Figure 1** up to a daily load between 182 - 365Wh depending on the geographic location of the site. It includes all standard appliances with a max. loading of 300W and max. surge loading of 750W, max. 20A 12V DC power supply.

Example Consumer Profile (solar regional factor = 5 kWh/m²/day)

Item	Quantity	Power / Unit (W)	Daily Operation (h)	Daily Load (Wh)
Energy Saving Lamp	2	9	4	72
TV / Video, Radio	1	60	4	180
Max. loading (loading factor = 1.0)		112		
Total daily consumer load				312
Total daily required energy demand (x 1.4)				436

Figure 1 - Lights and Appliances operated daily

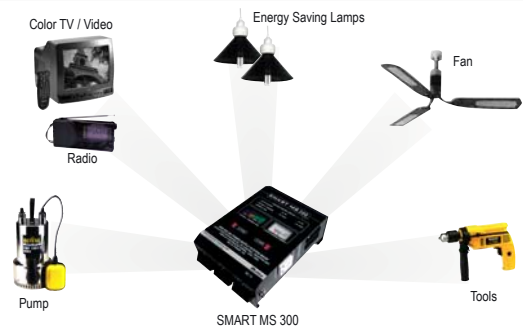

Description of Components

SMART MS 300

Compact "plug and play" Solar Home power supply system with newly developed solar charging and inverter system for easy installation. It can manage two independent 12V DC battery banks and a total of **30A** solar charging power. Thus the Solar Home System can be extended easily later on just by adding additional solar modules without changing the control unit. Furthermore the SMART MS 300 disposes of a **300W, 230V AC** resp. **115V AC - 50/60Hz** and **12V DC / 20A** power output for direct connection of DC/AC consumers.



Solar Module SM 85

Polycrystalline **85Wp / 12V** solar module with high-efficiency solar cells. Textured surface reduces sun light reflection and provides highest output. Top anti-hydroscopic and UV and ozone resistant sandwich with special tempered glass. Weather and waterproof foil provide highest life expectancy even under extreme climatic conditions: Ice, hail, snow, storm have no effect on the solar modules. The solar modules are designed to resist extreme humidity, heat and cold. Therefore these solar modules fit in all requirements for a reliable and professional use around the world.

Batterie SBV 80

The Standby Bull Block **80Ah (C=20h) / 12V** battery is a valve regulated lead acid battery, designed with AGM (Absorbed Glass Mats) technology, high performance plates and electrolyte to gain extra power output for common power backup system applications widely used in the field of UPS and in the Renewable Energy Sector. This battery guaranties many years of trouble free and safe operation. It is thus ideally suitable for the SMART hybrid power supply systems.

