

# SMART 2000 Power Supply System

## ▪ Solar Power Set IV

### Stand-Alone Solar AC/DC Power Supply

Independent "plug & play" solar energy system for standard 230 / 110V AC and 12V DC power supply. The power set consists of a compact **SMART SWHBG 2000** unit with built-in solar charge regulator and "true sine wave" inverter, a **solar generator** as charging system and a maintenance-free **battery bank** for energy storage. The set will be delivered as "installation-ready" power package and is thus provided with **mounting system for solar modules** and all necessary **cabling** for easy wiring.



### ▪ System Layout

### Main Components of Power Set

Component	Qty.	Description	Acknowledgements
Control / Inverter Unit	1	<b>SMART SWHBG 2000 S01</b> true sine 220-240V AC, 50Hz; 2200W cont. / 4500W surge power; 50A / 24V max. solar charging current, 50A / 24V max. wind / add. charging current; dimensions incl. roller rack (lxwxh): 460x420x230mm <sup>3</sup> ; net weight: 27.0kg	optional 110-120V AC, 60Hz 2 years warranty CE Declaration, ISO9001/2000
Solar Charging System	4	<b>Solar Module SM 125</b> monocrystalline with aluminium frame; 125Wp / 12V; dimensions (lxwxh): 1461x656x38mm <sup>3</sup> ; net weight: 15.2kg	5 years product warranty 25 years performance guarantee (80%) IEC, CE Declaration, TÜV
Storage System	2	<b>Battery SBV 150 / 12</b> maintenance-free AGM; 150Ah (C = 20h) / 12V; dimensions (lxwxh): 482x170x242mm <sup>3</sup> ; net weight: 44.2kg	1 year product warranty 10 years life expectancy CE Declaration, ISO9001/2000

### System Wiring Scheme

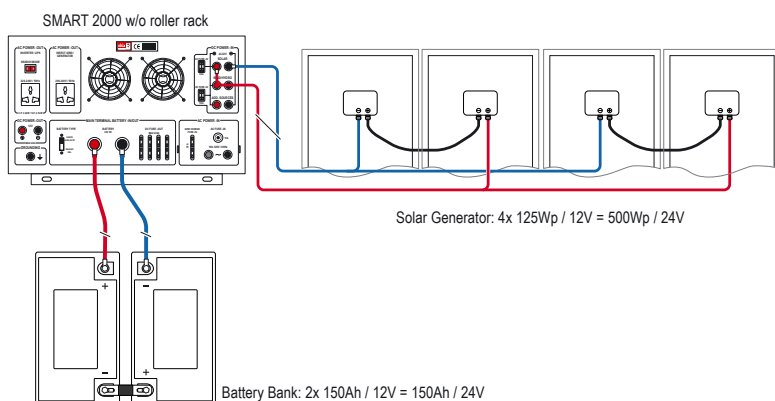

### System Summary / Technical Data

AC Power output:	cont. 2200W / surge 4500W
DC Power output:	20A / 12V
Battery Storage capacity:	150Ah / 24V
Installed PV Power:	500Wp
Avg. Daily PV Charging Capacity:	
3 kWh/m <sup>2</sup> /day	1500Wh
4 kWh/m <sup>2</sup> /day	2000Wh
5 kWh/m <sup>2</sup> /day	2500Wh
6 kWh/m <sup>2</sup> /day	3000Wh
Total weight of package:	approx. 195kg

## SMART 2000 Power Supply System

## - Solar Power Set IV

### System Performance

The Solar Power Set IV will supply 220-240V, 50Hz or 110-120V, 60Hz (true sine) lights and household appliances as shown in **Figure 1** up to a daily load between 1100 - 2200Wh depending on the geographic location of the site. It includes all standard household appliances with a max. loading of 2.2kW and max. surge loading of 4.5kW, max. 20A 12V DC power supply.

### Example Consumer Profile (solar regional factor = 5 kWh/m<sup>2</sup>/day)

Item	Quantity	Power / Unit (W)	Daily Operation (h)	Daily Load (Wh)
Energy Saving Lamp	3	11	4	132
TV / Video / SAT	1	80	4	320
Radio / HiFi	1	30	5	150
Fridge / Freezer	1	120	24	700
Fan	1	30	3	90
Pump	1	250	1	250
Drill	1	1000	0.16 (10 min)	160
<b>Max. loading (loading factor = 1.0)</b>		<b>1523</b>		
<b>Total daily consumer load</b>				<b>1802</b>
<b>Total daily required energy demand ( x 1.4 )</b>				<b>2522</b>

Figure 1 - Lights and Appliances operated daily

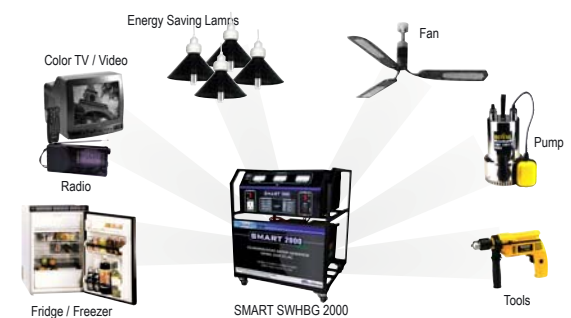

### Description of Components

#### SMART SWHBG 2000

Mobile grid-independent hybrid power control unit with built-in DC/AC true sine inverter for continuous **2.2kW** supply of **220-240V AC / 50Hz** resp. **110-120V / 60Hz** and **12V DC** appliances with max. **20A**. The system disposes of 2 built-in charge controllers for grid (20A / 24V) and for solar (50A / 24V). Wind and hydro charging systems can be connected by external charge controllers. Suitable for homesteads, offices, schools, hospitals etc. For grid-connected areas to be used as uninterrupted power supply system (UPS).



#### Solar Module SM 125

Monocrystalline **125Wp / 12V** solar module with high-efficiency solar cells. Textured surface reduces sun light reflection and provides highest output. Top anti-hydroscopic and UV and ozone resistant sandwich with special tempered glass. Wheater and waterproof foil provide highest life expectancy even under extreme climatic conditions: Ice, hail, snow, storm have no effect on the solar modules. The solar modules are designed to resist extreme humidity, heat and cold. Therefore these solar modules fit in all requirements for a reliable and professional use around the world.



#### Batterie SBV 150

The Standby Bull Block **150Ah (C=20h) / 12V** battery is a valve regulated lead acid battery, designed with AGM (Absorbed Glass Mats) technology, high performance plates and electrolyte to gain extra power output for common power backup system applications widely used in the field of UPS and in the Renewable Energy Sector. This battery guaranties many years of trouble free and safe operation. It is thus ideally suitable for the SMART hybrid power supply systems.

